

Project:		Catalog#:		Type:	
Prepared By:		Notes:		Date:	

E1LAL

LED Architectural Linear
CCT-selectable • Up/Down Lighting
3 Size Options • 5 Limited Year Warranty



Overview

Energetic Lighting's E1LAL series, an LED Linear Architectural solution featuring a modular system allows flexible configuration and creative design along with providing a modern geometric layout including clean lines with options in Black, Silver, and White to be utilized in multiple settings (Lobbies, Offices and Showrooms) to just name a few. Various mounting options are available to captivate any audience from Cable Suspended, Direct Ceiling Surface, Direct Wall Surface and/or Recessed Ceiling Mounting for maximum versatility and functionality.

An integral ezCCT field-selectable feature allows you to change to your desired color temperature with a simple switch located on the driver body with no hardware needed to access. Easy install and the latest performance LEDs with drivers, including a 5 year warranty the E1LAL will provide many years of dependability and maintenance-free lighting décor.

Applications

- Lobby
- Convention Center
- Retail Store
- Showroom
- Gymnasium
- Hotel
- Casino
- Office

Dimensions

- 2' E1LAL2-15D-93050 | E1LAL-2U-30D-93050
- 4' E1LAL4-30D-93050 | E1LAL-4U-40D-93050
- 8' E1LAL8-60D-93050 | E1LAL-8U-80D-93050

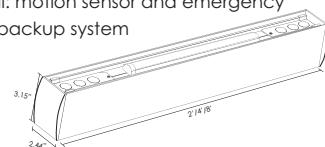

Office Suspended ceiling mount lighting for excellent and modern architectural design.

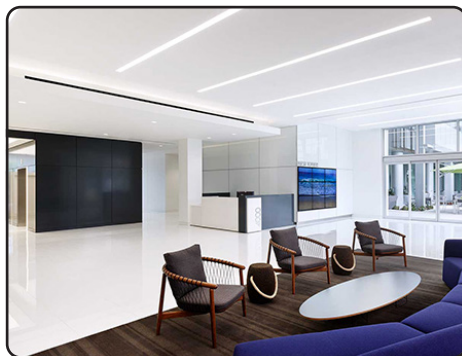

Lobby Recess wall or ceiling mount lighting for creative architectural design.

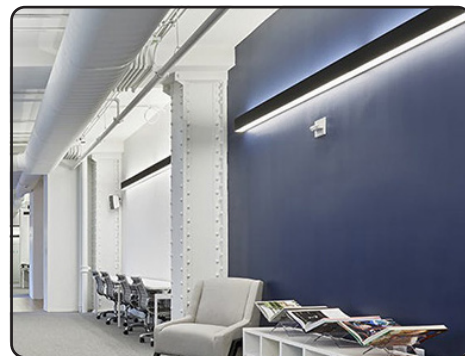

Direct wall or ceiling mount lighting for gracefull and elegant decor for any workspace/showroom.



Signature curved Endcap design with a clean extruded aluminum construction.



An extraordinary latching system within the body of the fixture.



An ezCCT field-selectable feature allows you to change to your desired color temperature



An secondary Lens of indirect light feature is available for better light distribution and extra decor on all suspended or wall mounted design.



Connecters include L, T, X, Y, and V junctions that provide a seamless and continuous design.

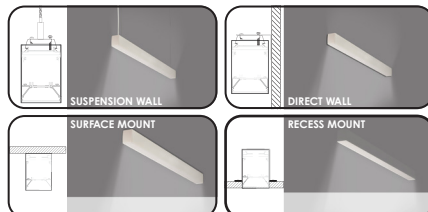

Various mounting options are available from Cable Suspension, Direct Ceiling Surface, Direct Wall Surface and Recessed Ceiling Mounting.

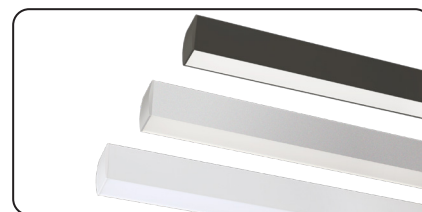

Available in three color options of Black, Silver, and a White base model for clean and sleek modern design.

Mounting/Accessories

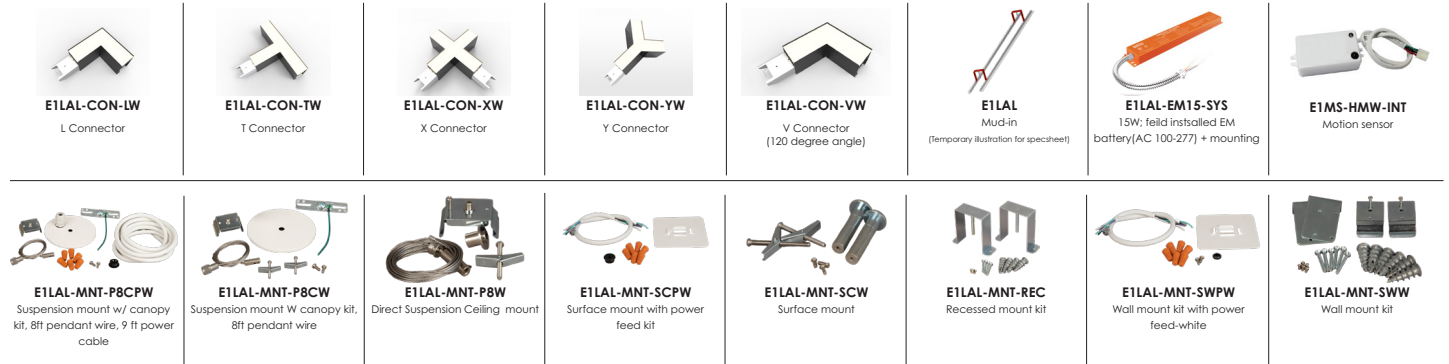

Load Information

Input Voltage	120 Vac
Power Factor	>0.9
THD	<20%
Low Temp Start	-20°C (-4°F)
Max Temp	40°C (104°F)
Unit Weight	2' 3.5 lbs 4' 7.7 lbs 8' 8 lbs

Shipping Information

Item	Weight	Box Qty.
2'	4.6 lbs	4 per case
4'	8.8 lbs	4 per case
8'	18 lbs	2 per case

Lumen Maintenance

Housing Type	Ambient Temperature	TM-21 Lumen Maintenance (50,000 hours)	Theoretical L70 (hours)
2' profile	25°C	>91.39%	54,000
4' profile	25°C	>91.39%	54,000
8' profile	25°C	>91.39%	54,000

Model Ordering Number Breakdown

Series Prefix	Size	Optics	Wattage	Optics	CRI	CCT
E1LAL	2	U	30	D	9	3050
E1LAL LED Linear Architectural Lighting CCT-selectable	2 2FT 4 4FT 8 8FT	U Uplight Blank No Uplight	15 15W 20 20W 30 30W 40 40W 60 60W 80 80W	D 0-10V Dimmable	9 90 CRI	3000 3000K, 4000K, 5000K

Ordering Examples:

1. For E1LAL 15W Selectable CCT Fixture 100-277V	Model#: E1LAL2-15D-93050
2. For E1LAL 15W Selectable CCT Fixture 100-277V with L Module Connector + Wall Mount Kit with Power Feed Kit- White + 15W; AC 100-277 EM Battery & M	Model#: E1LAL2-15D-93050
REFER TO PAGE 4 FOR MOUNTING & SENSOR OPTIONS	E1LAL-CON-LW E1LAL-MNT-SWPW E1LAL-EM15-EM-SYS

STOCK ORDER INFORMATION

CCT Selectable 2' Profile 100-277V

2' Profile

Model Number	Order#	Lumens	Wattage	LPW	Color Temp	CRI	Voltage	Dimming	DLC	Pallet Qty
E1LAL2-15D-93050	30160	1,950LM	15W	130	3000K, 4000K,	90	120-277V	0-10V	DLC-P	TBA
E1LAL2U-20D-93050	30163	2,600LM	20W	130	5000K CCT	90	120-277V	0-10V	DLC-P	TBA

CCT Selectable 4' Profile 100-277V

4' Profile

Model Number	Order#	Lumens	Wattage	LPW	Color Temp	CRI	Voltage	Dimming	DLC	Pallet Qty
E1LAL4-30D-93050	30161	3,900LM	30W	130	3000K, 4000K,	90	120-277V	0-10V	DLC-P	TBA
E1LAL4U-40D-93050	30164	5,200LM	40W	130	5000K CCT	90	120-277V	0-10V	DLC-P	TBA

CCT Selectable 8' Profile 100-277V

8' Profile

Model Number	Order#	Lumens	Wattage	LPW	Color Temp	CRI	Voltage	Dimming	DLC	Pallet Qty
E1LAL8-60D-93050	30162	7,800LM	60W	130	3000K, 4000K,	90	120-277V	0-10V	DLC-P	TBA
E1LAL8U-80D-93050	30165	10,400LM	80W	130	5000K CCT	90	120-277V	0-10V	DLC-P	TBA

Optional Accessories

Model Number	Order #	Description
E1LAL-MNT-P8CPW	30173	Suspension mount with canopy Kit, 8ft pedant wire, 9ft power cable
E1LAL-MNT-P8CW	30184	Suspension mount with canopy Kit, 8ft pedant wire (No power cable)
E1LAL-MNT-P8W	30174	Suspension mount without canopy (No power cable, no canopy) 8ft pendant wire
E1LAL-MNT-SCPW	30175	Surface mount with power feed Kit
E1LAL-MNT-SCW	30176	Surface mount without power feed Kit
E1LAL-MNT-REC	30177	Recessed mount kit
E1LAL-MNT-SWPW	30178	Wall mount kit with power feed Kit - white
E1LAL-MNT-SWW	30179	Wall mount kit without power feed Kit - white

Optional Connectors/EM Battery/Sensor

Model Number	Order #	Description
E1LAL-CON-LW	30166	L Connector
E1LAL-CON-TW	30167	T Connector
E1LAL-CON-XW	30168	X Connector
E1LAL-CON-YW	30182	Y Connector
E1LAL-CON-VW	30183	V Connector (120 degree angle)
E1LAL-EM15-SYS	30172	15W; AC 100-277V EM Battery + Mounting
E1LAL-EM-RMT	30170	Remote control for EM battery (E1LAL-EM15)
E1LAL-EM15	30169	15W; AC 100-277V; Including Input metal conduit length 0.65M
MTO-CLR-LAL	30180	Black and Silver color for custom order
E1MS-HMW-INT	98053	Integral Motion Sensor
E1MS-HMW-RC	98054	Motion Sensor Control

PHOTOMETRIC DATA

Model: E1LAL2-15D-93050
 Test Report: E1LAL2-15D-93050.ies
 CCT: 3000
 Lamp Type: LED
 Lumens: 1950 LM
 Input Watts: 15 W
 IESNA: Type-VS
 Efficacy: 130 LM/W

Lumen Intensity Graph:

E1LAL2-15-93050

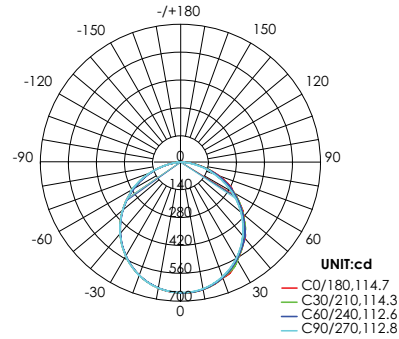

AVERAGE BEAM ANGLE(50%):113.6 DEG

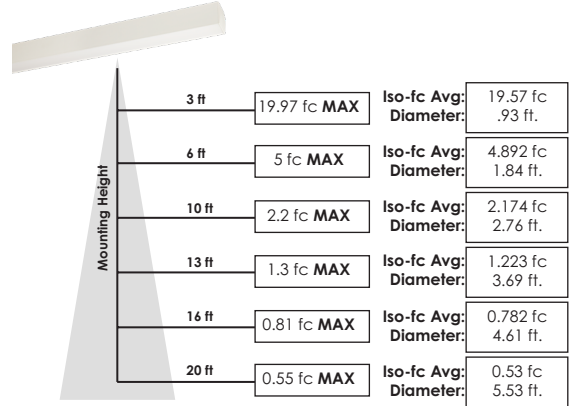

Model: E1LAL4-30D-93050
 Test Report: E1LAL4-30D-93050.ies
 CCT: 3000
 Lamp Type: LED
 Lumens: 3900 LM
 Input Watts: 30 W
 IESNA: Type-VS
 Efficacy: 130 LM/W

Lumen Intensity Graph:

E1LAL4-30-93050

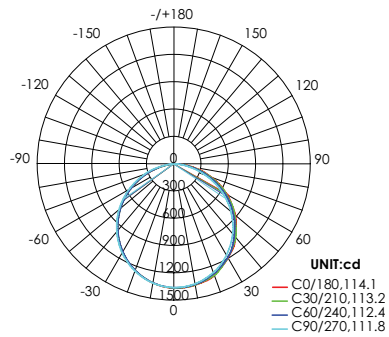

AVERAGE BEAM ANGLE(50%):112.9 DEG

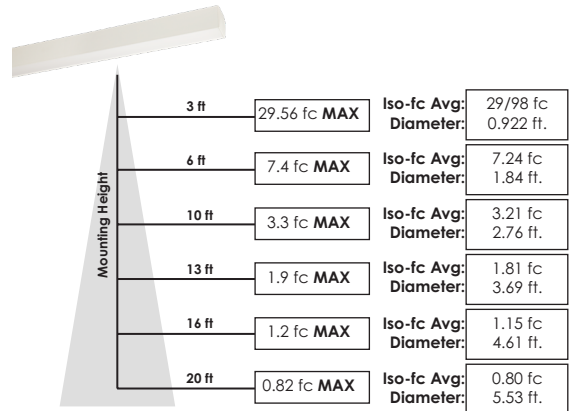

PHOTOMETRIC DATA

Model: E1LAL2-U20D-93050
 Test Report: E1LAL2U-20D-93050.ies
 CCT: 3000
 Lamp Type: LED
 Lumens: 2600 LM
 Input Watts: 20 W
 IESNA: Type-VS
 Efficacy: 130 LM/W

Lumen Intensity Graph:
E1LAL2-20-93050

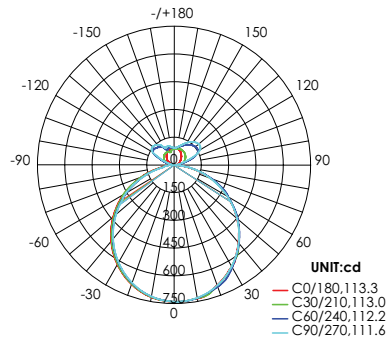

AVERAGE BEAM ANGLE(50%):112.6 DEG

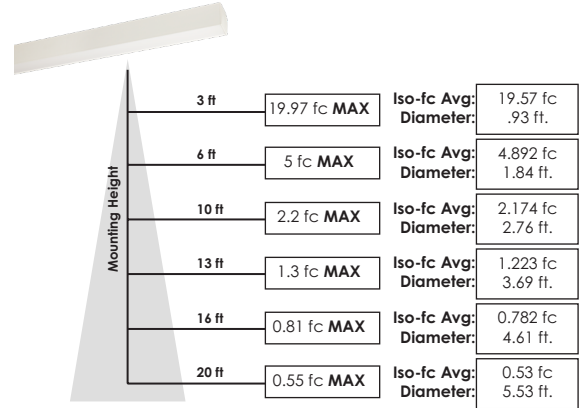

Model: E1LAL4U-40D-93050
 Test Report: E1LAL4U-40D-93050.ies
 CCT: 3000
 Lamp Type: LED
 Lumens: 5200 LM
 Input Watts: 40 W
 IESNA: Type-VS
 Efficacy: 130 LM/W

Lumen Intensity Graph:
E1LAL-4-40-93050

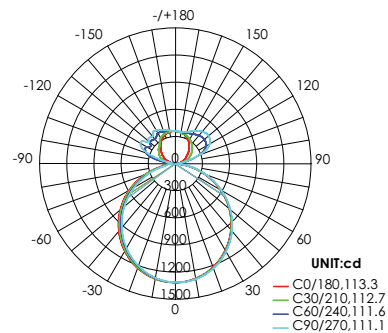

AVERAGE BEAM ANGLE(50%):112.1 DEG

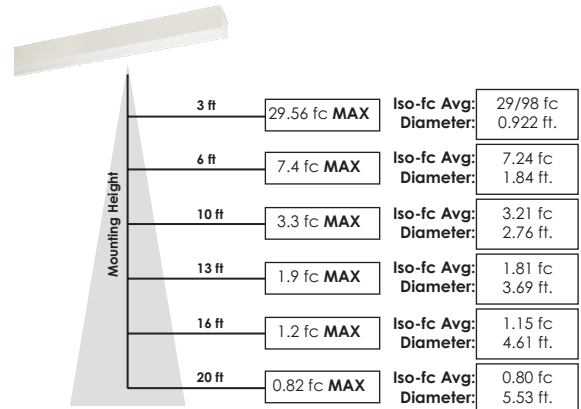

Fixture Layout

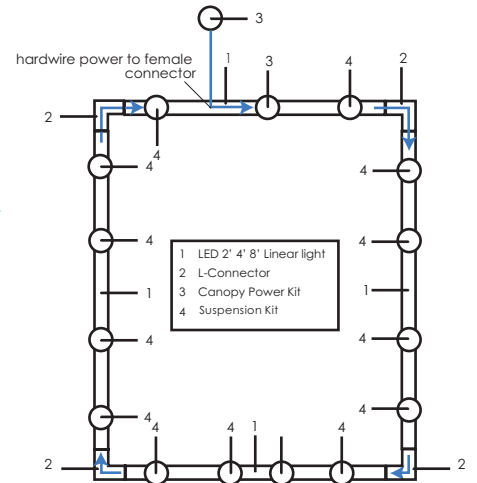

E1LAL 2' 4' 8'
ex. E1LAL2-15D-93050



L-Connector
E1LAL-CON-LW
#30166



Canopy Power Kit
E1LAL-MNT-P8CW
#30173



Suspension Kit
E1LAL-MNT-P8W
#30174

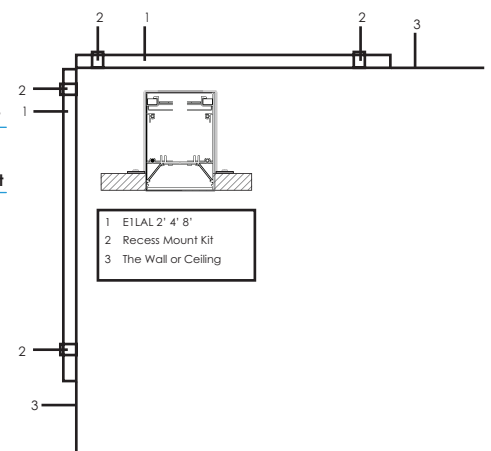
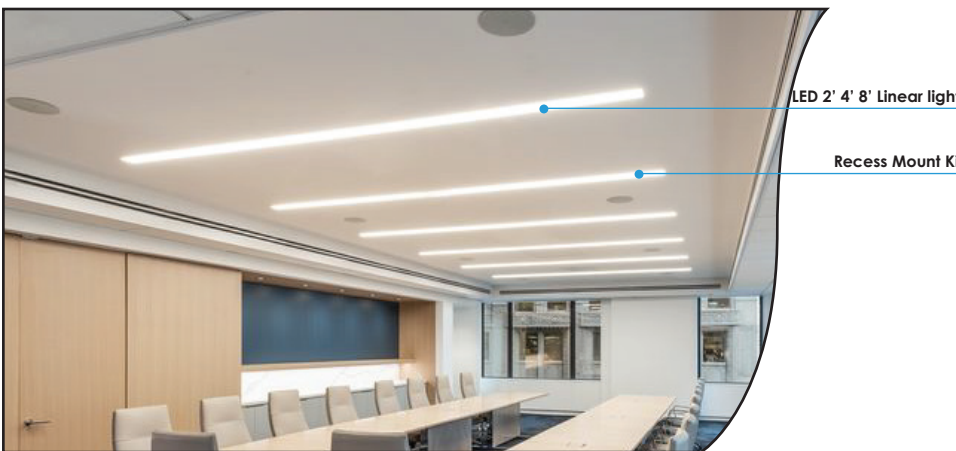
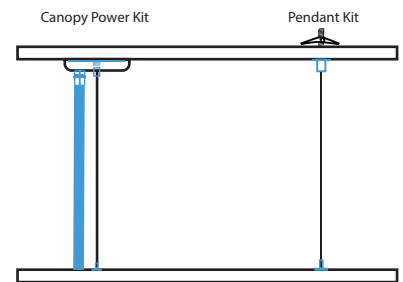

E1LAL 2' 4' 8'
ex. E1LAL2-15D-93050



Recess Mount Kit
E1LAL-MNT-REC
#30177



Recess Mount Kit

Recess Mount Kit



Wall Mount

LED 2' 4' 8' Linear light

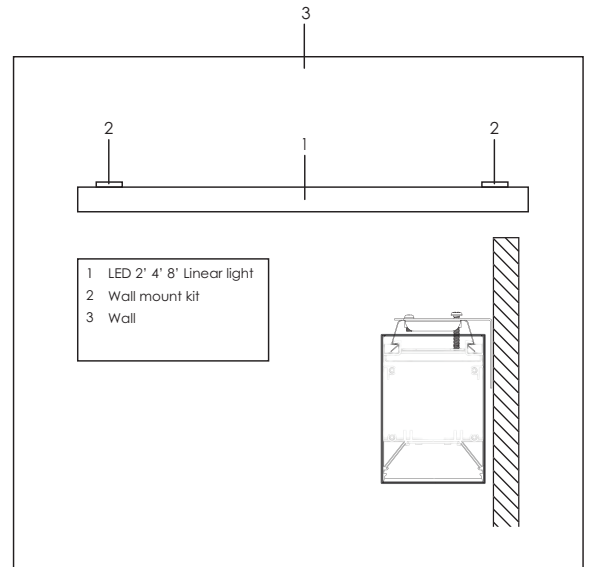

E1LAL 2' 4' 8'
ex. E1LAL2-15D-93050



Wall Mount
E1LAL-MNT-SWW
#30179

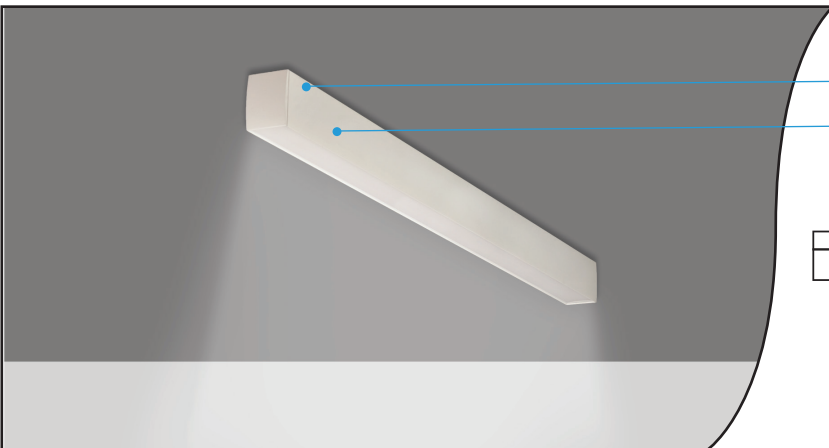

Surface Mount Kit

LED 2' 4' 8' Linear light

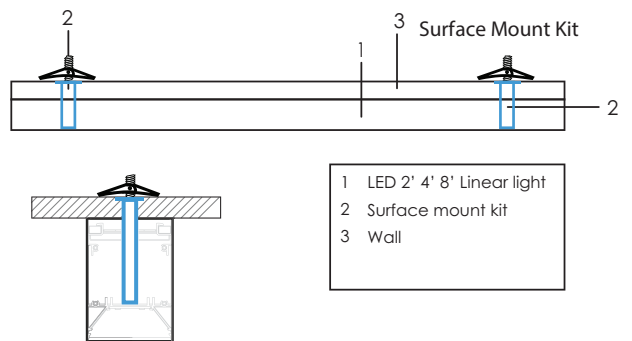

E1LAL 2' 4' 8'
ex. E1LAL2-15D-93050



Surface Mount Kit
E1LAL-MNT-SCW
#30176

Accessories Dimensions

E1LAL-MNT-P8CPW Suspension mount w canopy kit, 8ft pendant wire, 9ft power cable

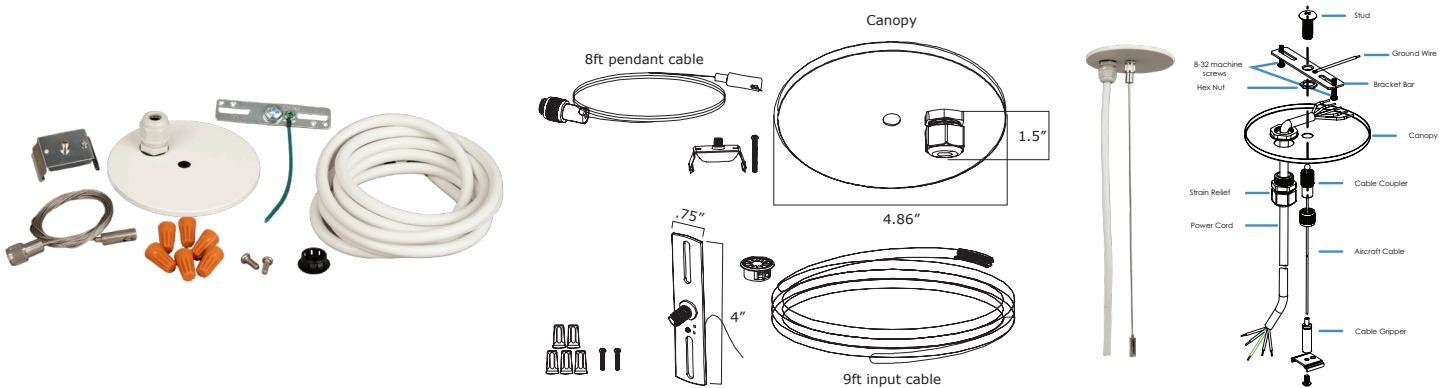

E1LAL-MNT-P8CW Suspension mount with (No power cable) Canopy Kit, 8ft pendant wire

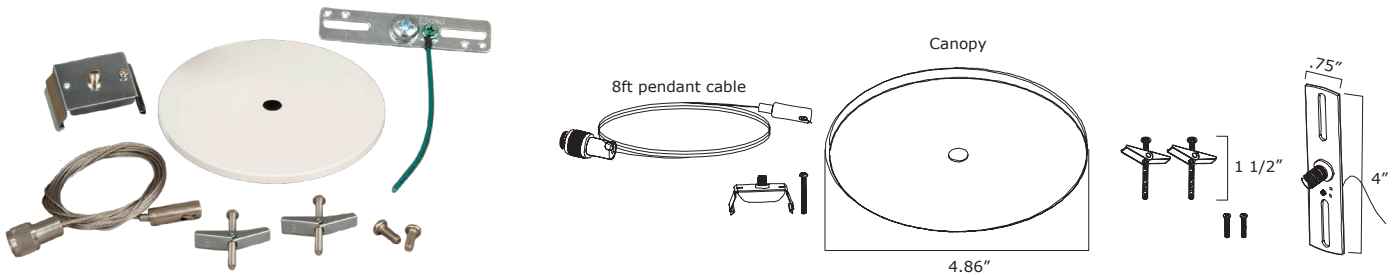

E1LAL-MNT-P8W Suspension mount with (No power cable, no canopy) 8ft pendant wire

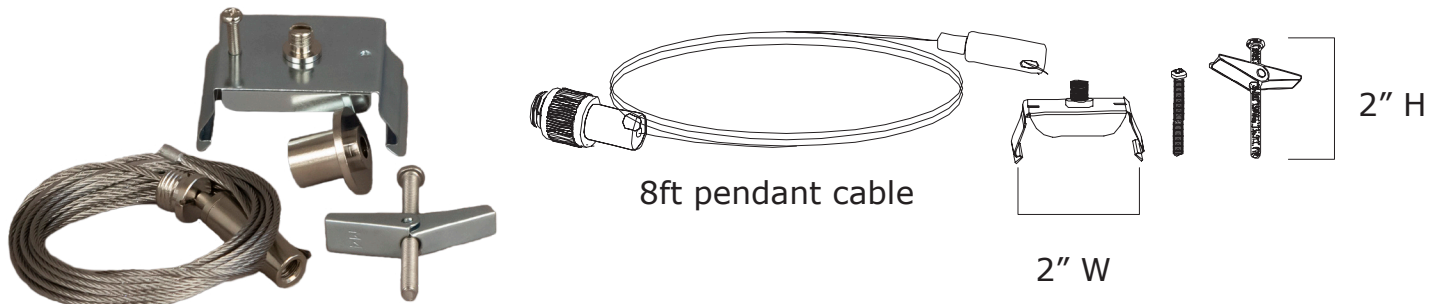

Accessories Dimensions

E1LAL-MNT-SCPW Surface mount with power feed kit

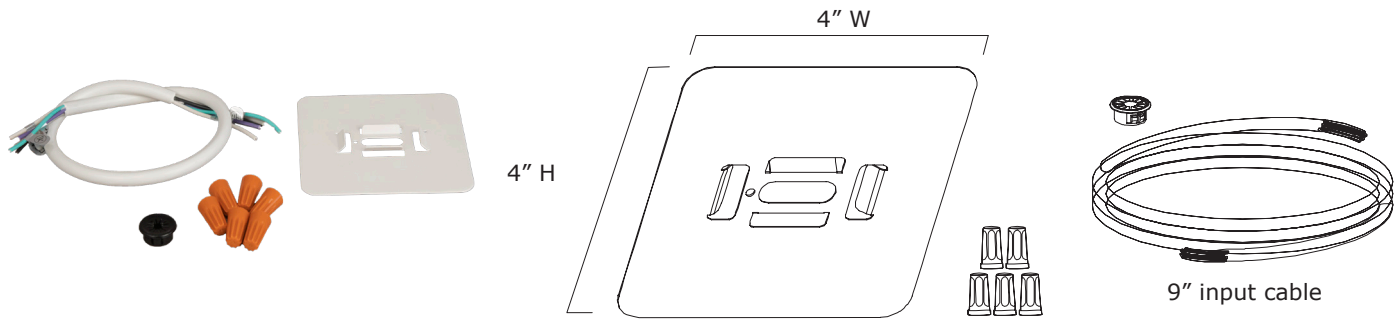

E1LAL-MNT-SCW Surface mount without power feed kit

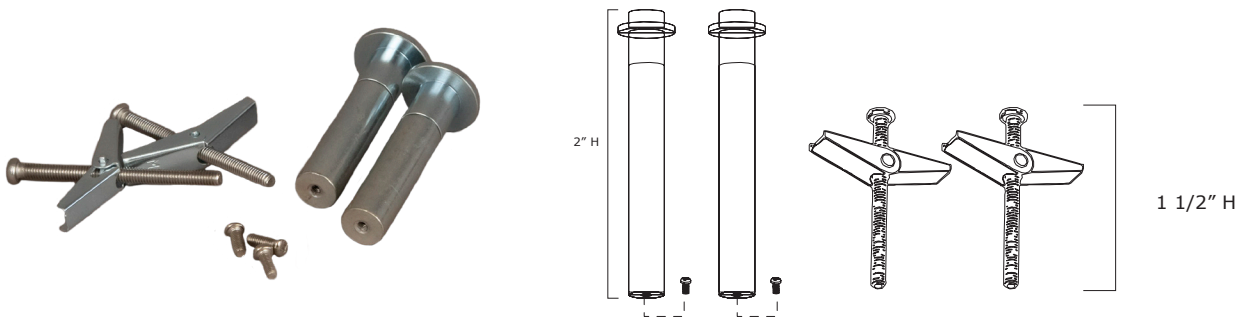

E1LAL-MNT-REC Recessed mount kit

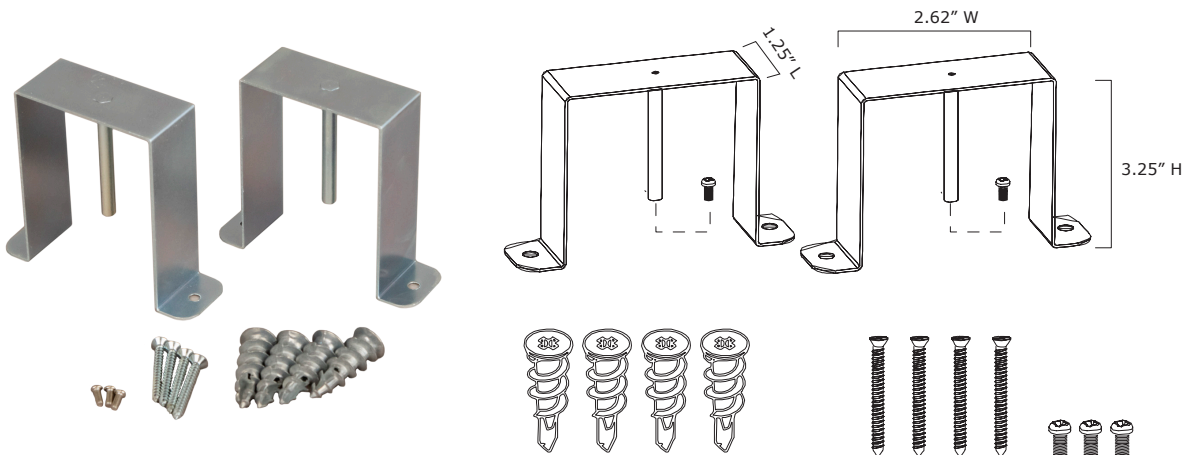

Accessories Dimensions

E1LAL-MNT-SWPW Wall mount kit with power feed kit-white

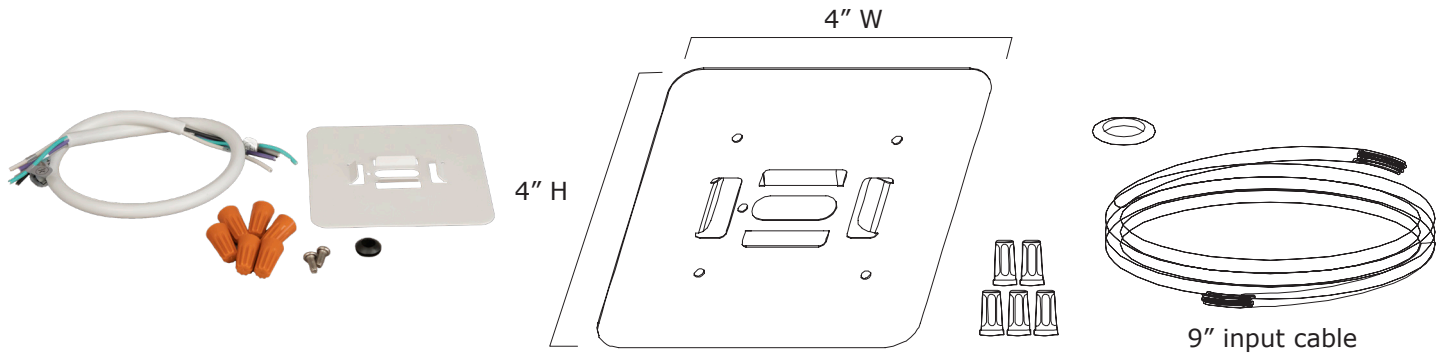

E1LAL-MNT-SWW Wall mount kit without power feed kit - white

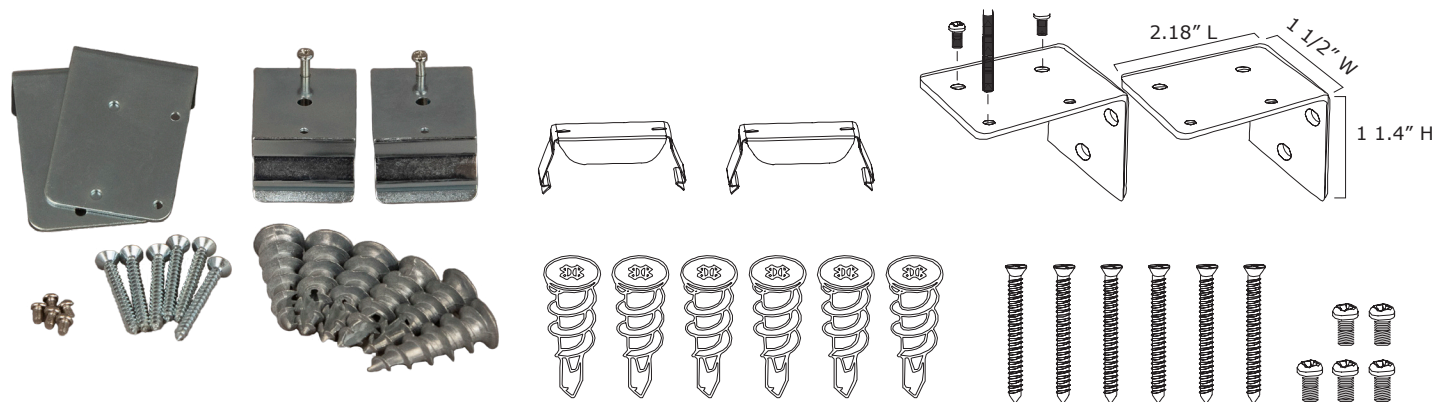

E1LAL-CON-LW L Module

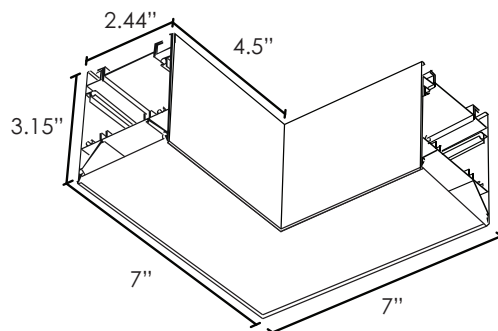

Accessories Dimensions

E1LAL-CON-TW T Module

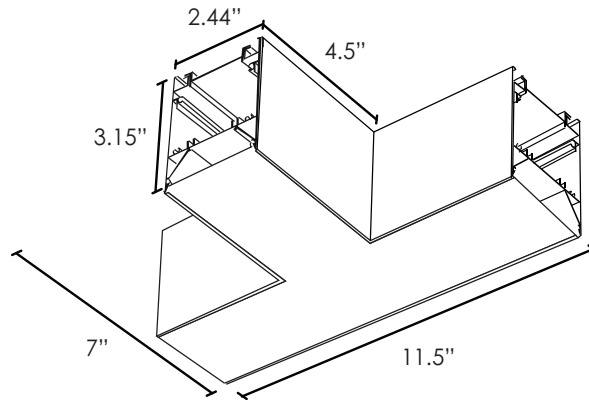

E1LAL-CON-XW X Module

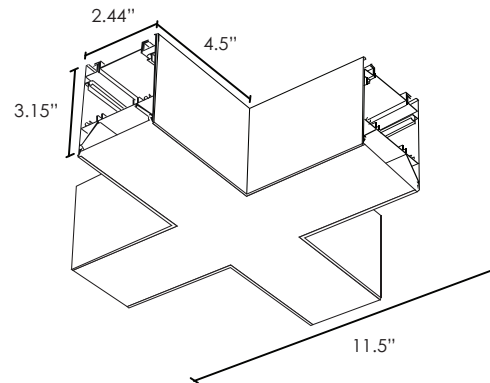
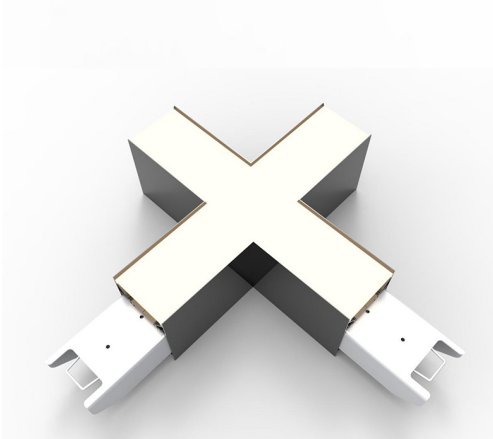

E1LAL-CON-XW Y Module

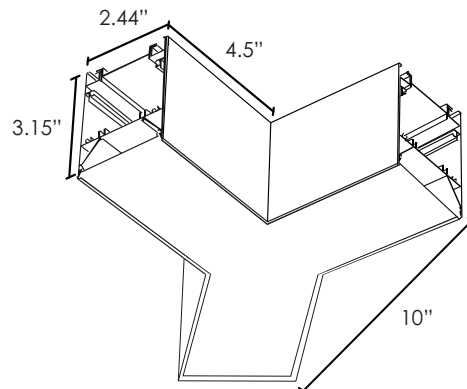

Accessories Dimensons

E1LAL-CON-XW V Module

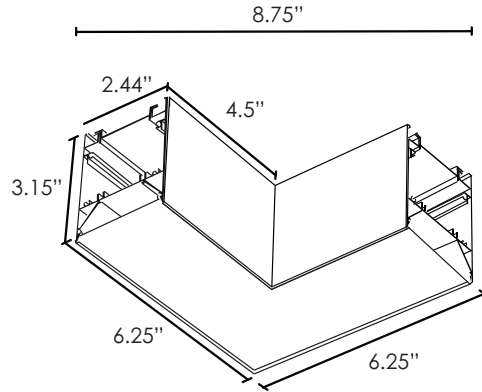
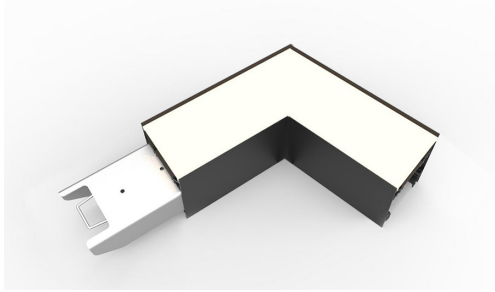

E1LAL Mud-In

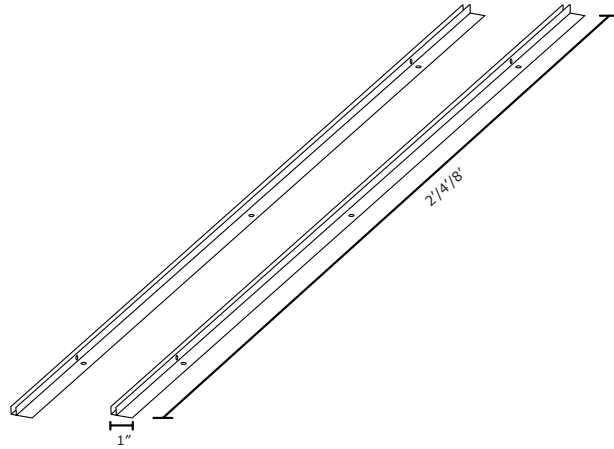
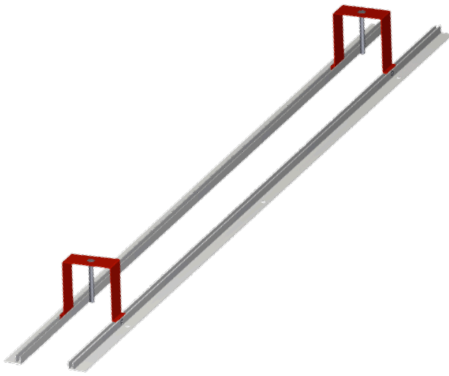

E1LAL-EM15-SYS 15W; AC 100-277V EM Battery + Remote Control

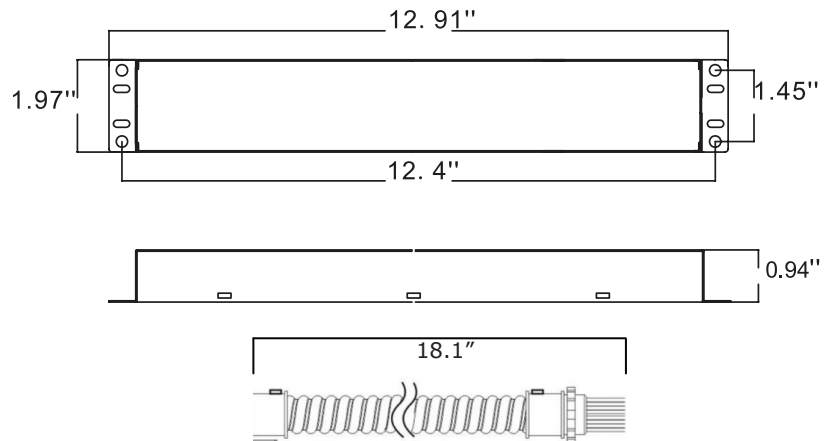



ENERGETIC
L I G H T I N G

E1LAL

LED Linear Architectural Lighting
CCT-selectable • 5 Year Warranty

NOTES:



ENERGETIC
L I G H T I N G

E1LAL

LED Linear Architectural Lighting
CCT-selectable • 5 Year Warranty

NOTES: